

# SLB

## SLIM LINE BATTEN

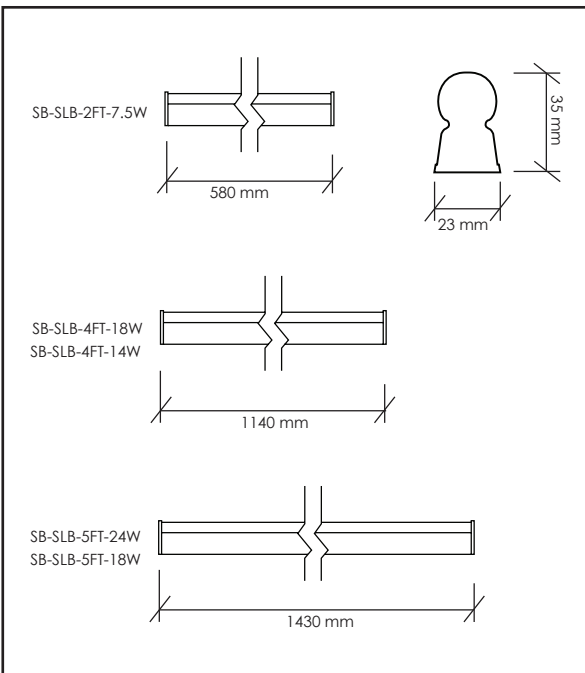
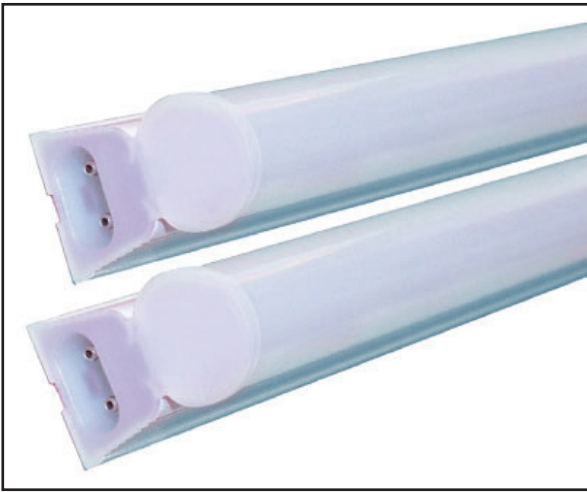

TECHNICAL DRAWING

### DESCRIPTION

SLB is an energy efficient alternative for fluorescent lighting systems. The fittings are slim line and offer a higher level of light output to their fluorescent counterparts. The fitting can replace a fluorescent tube in a fitting or an entire fluorescent fitting.

### LUMINAIRE INFORMATION

#### LUMINAIRE

Power	7.5W, 14W, 18W, 24W	
Input power	240V/50HZ	
Delivered Lumens (@5000°K)	7.5W	900 lm
	14W	1700 lm
	18W	2100 lm
	24W	2800 lm
Delivered Lumens (Tri-colour, 3000°K~5000°K)	7.5W	800~850lm
	14W	1500~1600lm
	18W	1900~2100lm
	24W	2550~2650lm
Colour Temperature	-4000°K/5000°K/6500°K	
	-Colour switching modules also available on request (Tri-Colour)	

### TECHNICAL INFORMATION

IP rating	IP20
Luminous Efficacy	115 lm/W
Luminous Efficacy (Tri-colour)	105~110 lm/W
CRI	Ra80+
Dimmable	0-10V
Rated operating life	50,000hrs
Warranty	3 Years
Approvals	ESS and VEET approved

### DIMENSIONS

MODEL	WATTS	DIMENSION (W X H X L)
SB-SLB-2FT-7.5W	7.5W	23 X 35 X 580 mm
SB-SLB-4FT-14W	14W	23 X 35 X 1140 mm
SB-SLB-4FT-18W	18W	23 X 35 X 1140 mm
SB-SLB-5FT-18W	18W	23 X 35 X 1430 mm
SB-SLB-5FT-24W	24W	23 X 35 X 1430 mm

Product information: The descriptors and illustrations in this publication apply to the specific products and models described as at the date of issue. Under our policy of continuous product development, product specifications may change without notice. Prospective purchasers should therefore check with their supplier to ensure this publication correctly describes the products that are being offered for sale. All information supplied is to be used for general reference purposes only and is on the understanding that Smart Bright will not be liable for any loss, liability or damage of whatever kind arising as a result of reliance on such information. Colours of products illustrated are as close as printing limitations allow. Smart Bright will at all times comply with its obligations pursuant to law including Trade Practices (Australian Consumer Law) Act and Regulations.

