

UFO2 HIGHBAY



DESCRIPTION

UFO is a low cost, industrial LED highbay that offers an energy efficient alternative to traditional HID fittings. Suitable for lighting areas such as factories, warehouses, car parks and other commercial applications they are available in 80W, 100W, 125W and 150W models. The microwave sensor version enables it to turn on only when movement is detected, further increasing its energy efficiency.

LUMINAIRE INFORMATION

LUMINAIRE

Power	80W, 100W, 135W, 150W (w microwave sensor), 100W
Input power	240V/50HZ
Delivered Lumens (@6500°K)	
SB-UFO2-MW-80W	11 360 lm
SB-UFO2-MW-100W	14 200 lm
SB-UFO2-MW-125W	17 750 lm
SB-UFO2-MW-150W	21 300 lm
OPT-UFO1-100W	25 560 lm
Colour Temperature	6500°K other colour temperatures also available on request

TECHNICAL INFORMATION

Beam angle	120°
Luminous Efficacy	148 lm/W
IP rating	IP20
CRI	Ra80+
Dimmable	0-10V
Flex and plug	Yes
Sensor	Microwave sensor for 80W model
Rated operating life	50,000hrs
Warranty	5 Years
Approvals	ESS and VEET approved

DIMENSIONS

MODEL	WATTS	DIMENSION (DIA X HEIGHT)
SB-UFO2-MW-80W	80W	Ø265 X 170 mm
SB-UFO2-MW-100W	100W	Ø265 X 170 mm
SB-UFO2-MW-125W	125W	Ø320 X 175 mm
SB-UFO2-MW-150W	150W	Ø320 X 175 mm
OPT-UFO1-100W	100W	Ø380 X 230 mm

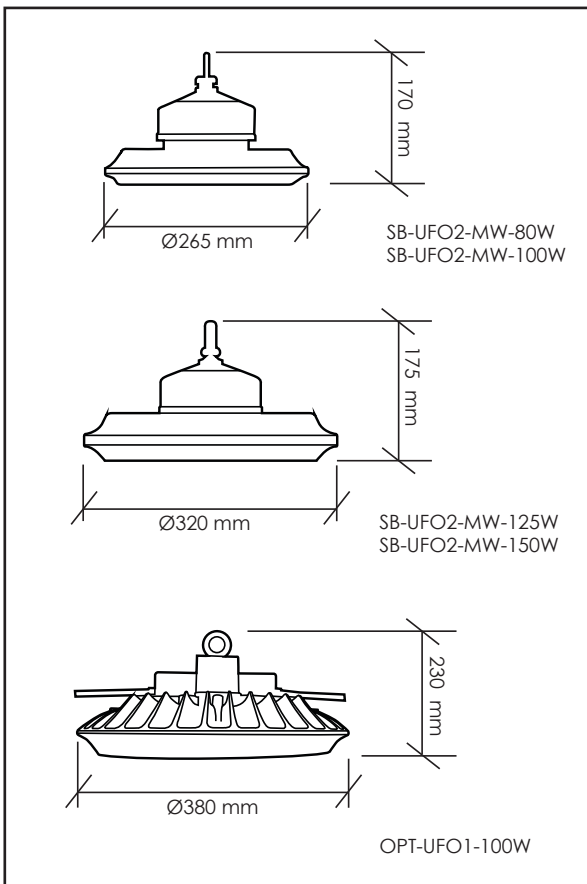

TECHNICAL DRAWING

Product information: The descriptors and illustrations in this publication apply to the specific products and models described as at the date of issue. Under our policy of continuous product development, product specifications may change without notice. Prospective purchasers should therefore check with their supplier to ensure this publication correctly describes the products that are being offered for sale. All information supplied is to be used for general reference purposes only and is on the understanding that Smart Bright will not be liable for any loss, liability or damage of whatever kind arising as a result of reliance on such information. Colours of products illustrated are as close as printing limitations allow. Smart Bright will at all times comply with its obligations pursuant to law including Trade Practices (Australian Consumer Law) Act and Regulations.

